



This information is brought to you by  
Owls Hall Environmental working in  
partnership with Klargester products.



*Excellent Treatment*

**0845 375 1801**  
[www.ohel.co.uk](http://www.ohel.co.uk)

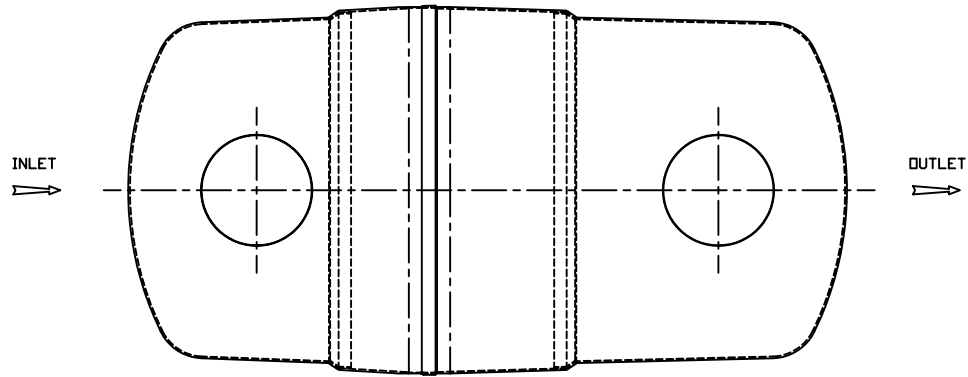

NOTES :-

1. UNITS CAN BE PROVIDED WITH EXTENSION SHAFTS IN 0.5Mtr INCREMENTS.
2. STANDARD INLET/OUTLET PIPES ARE Ø160 PVCu UNDERGROUND DRAINAGE TO BS4660, FOR OTHER PIPE SIZES AND TYPES AVAILABLE CONSULT KLARGESTER.

3. IT IS ESSENTIAL THAT THIS DRAWING IS READ IN CONJUNCTION WITH DATA SHEET PD----- (SUPPLIED WITH UNIT) GIVING INSTALLATION DETAILS. THIS DRAWING SHOULD BE USED FOR DIMENSIONAL INFORMATION ONLY

WORKING CAPACITY.	APPROX WEIGHT		FALL ACROSS UNIT	LENGTH DIM 'A'
	EMPTY	FULL		
8000 LTS	550	8550	50	3200
10000 LTS	640	10640	50	3915
12000 LTS	730	12730	50	4640
15000 LTS	875	15875	50	5435
19000 LTS	1110	20110	50	6865

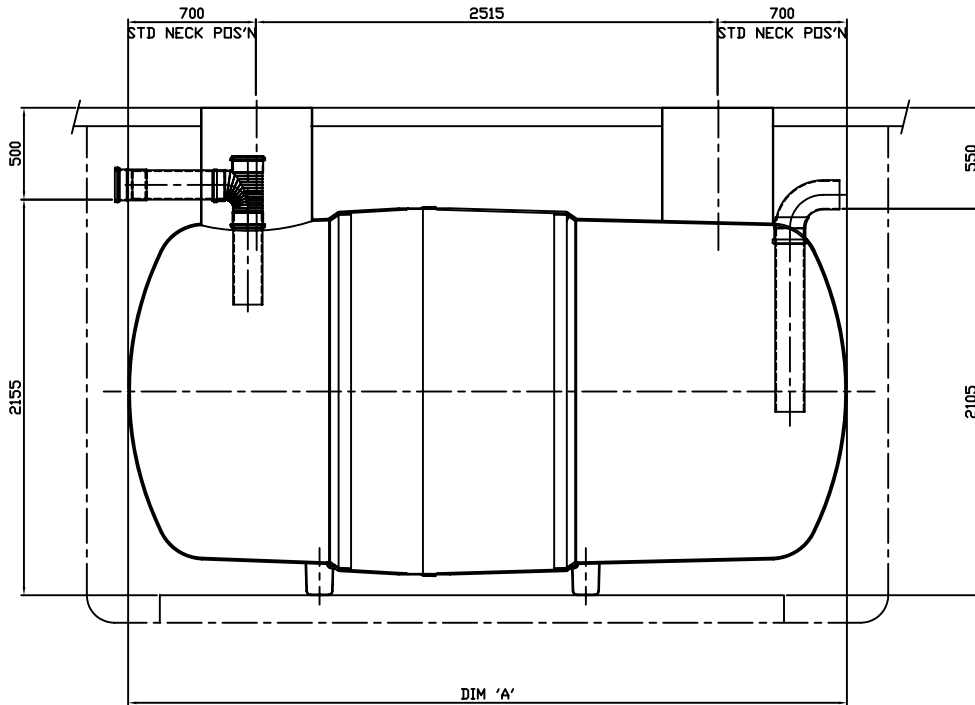

PART SECTION ON C.L.

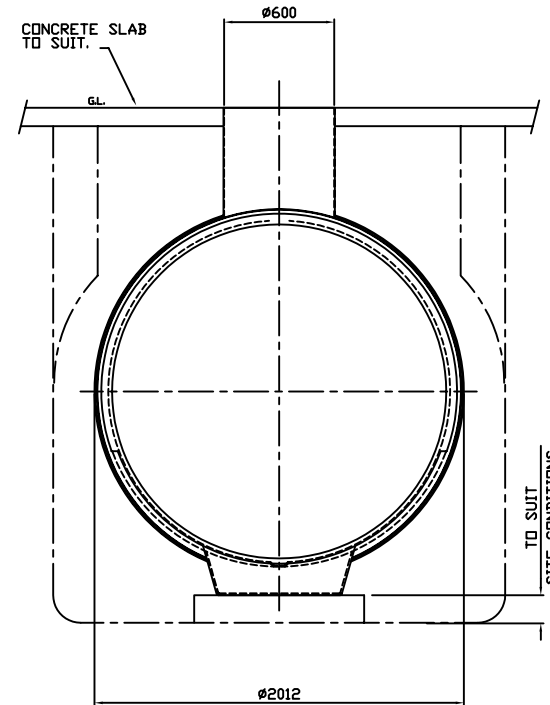

ALL DIMENSIONS ARE IN MILLIMETRES - DO NOT SCALE



Klargester Environmental Ltd.  
College Road North, Aston Clinton,  
Aylesbury, Bucks. HP22 5EW.  
Tel:- 01296 633000  
www.klargester.co.uk

TITLE  
**1.8Ø RANGE**  
8000 - 19000 LITRE  
GREASE SEPARATORS  
CUSTOMER DRAWING

SCALE: 1:15 SHEET SIZE: A1

DRAWING No. DS0655 ISSUE: 1

ISSUE	DATE	DRAWN	MODIFICATION
1	22.05.03	A.L.	INITIAL ISSUE

This drawing is copyright and may not be reproduced or used without the written permission of Klargester Environmental Ltd. KLARGESTER RESERVE THE RIGHT TO CHANGE SPECIFICATIONS WITHOUT NOTICE

