

SCRAP VIEW

IMPORTANT TO TRANSFER ANY COVER LOADS THROUGH TO BACKFILL i.e. CONCRETE TO BE FREE OF ANY VOIDS UNDER G.R.P. TOP FLANGE.

SURROUNDING FLOOR SLAB SHOULD HAVE AN ADEQUATE FALL TO ALLOW WASTE WATER TO RUN INTO SILT TRAP

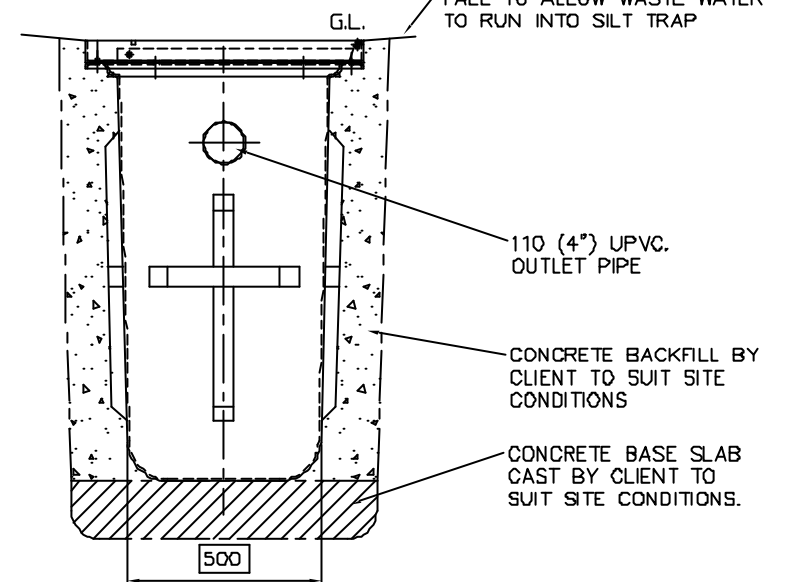

110 (4") UPVC. OUTLET PIPE

CONCRETE BACKFILL BY CLIENT TO SUIT SITE CONDITIONS

CONCRETE BASE SLAB CAST BY CLIENT TO SUIT SITE CONDITIONS.

NOTES:-

- 1.) GALVANISED MESH COVERS (HEAVY DUTY). MAX LOADING - 4000Kg/200mmx200mm.
- 2.) THIS DRAWING IS ALSO AVAILABLE ON OUR WEBSITE www.klargester.com

ISSUE	DATE	DRAWN	MODIFICATION
6	09.11.05	SnP	CC306 - Note 2 Added
5	21.10.04	A.L.	NEW BORDER / DIMENSIONS ADDED
4	28.08.95	S.T.	NEW COVER / FRAME ASSEMBLY
3	15.11.94	J.A.H.	CORRECT COVER SHOWN
2	07.02.92	R.F.M.	UPDATED TO SHOW INSTALLATION DETAIL
1	30.07.91	M.P.L.	INITIAL ISSUE

This drawing is copyright and may not be reproduced or used without the written permission of Klargester Environmental
 KLARGESTER RESERVE THE RIGHT TO CHANGE SPECIFICATIONS WITHOUT NOTICE

ALL DIMENSIONS ARE IN MILLIMETRES - DO NOT SCALE

Klargester
Treatment Systems
 Klargester Environmental
 College Road North, Aston Clinton,
 Aylesbury, Bucks. HP22 5EW.
 Tel:- 01296 633000
www.klargester.com

TITLE	
CAR WASH SILT TRAP CUSTOMER DRAWING	
SCALE	SHEET SIZE
1:10	A2
DRAWING No.	ISSUE
800341	6

